

Typical Above Ground (Mounded) System

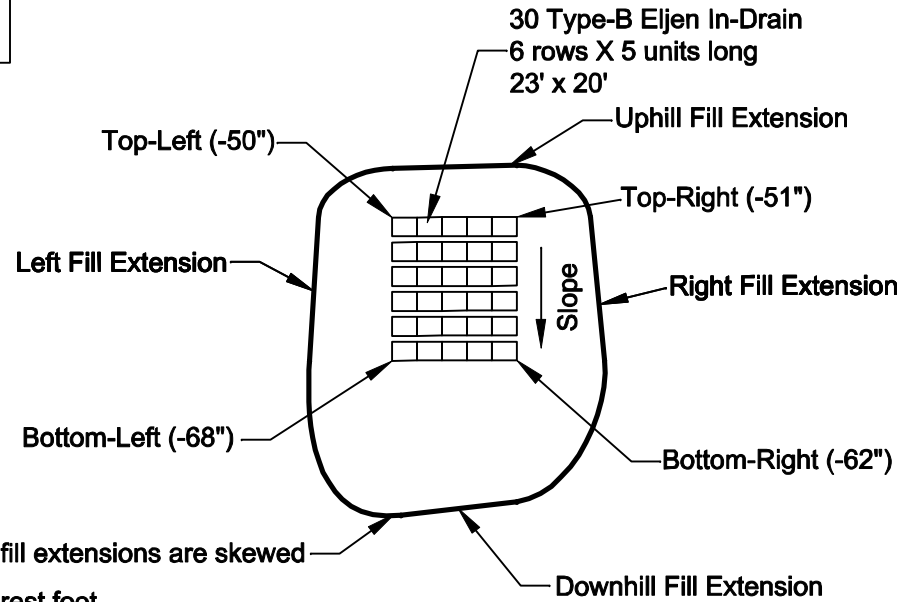

Note: Fill extension lengths are calculated exactly and rounded to the nearest foot.

Partially Buried System - Typical on a well-drained sandy hillside

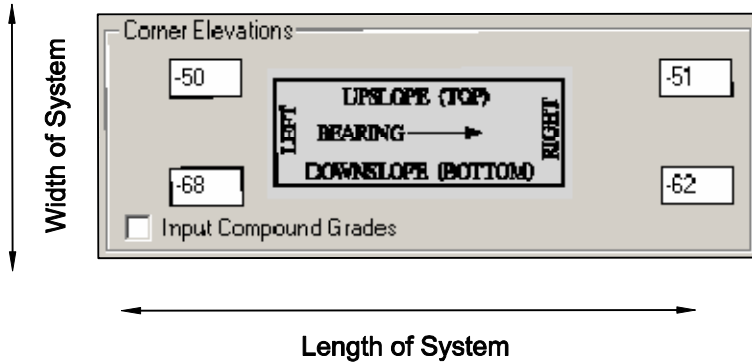
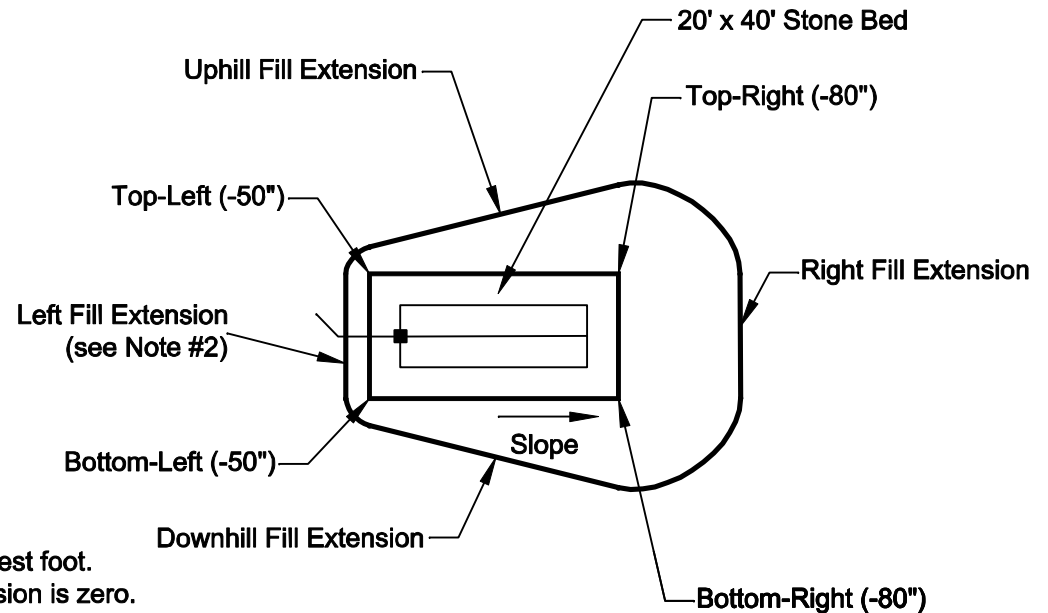
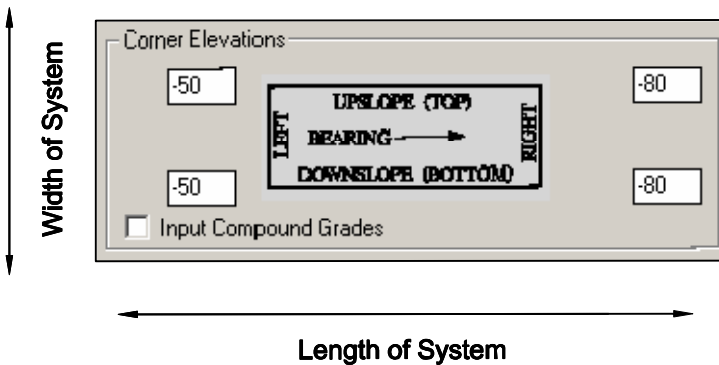

Notes:

1. Fill extension lengths are calculated exactly and rounded to the nearest foot.
2. If corner/side of the system is buried, then the length of the fill extension is zero.
For drafting clarity the length of the fill extension is set to the width of the fill shoulder.

How to enter Compound Grades

The following figures demonstrate how to enter Compound Grades into SeptiCAD.

Figures 1a & 1b. A simple compound slope located down hill of a disposal field.

Figures 2a & 2b. A more complex version of Figure 1a & 1b.

Figures 3a & 3b. Disposal field on the top of hill.

Compound Grades - Figure 1a

LEGEND

- Corner Elevations (REQUIRED)
- ⊕ User Defined Spot Elevation (See Note 1)
- Auto-calculated Spot Elevation (See Note 1)

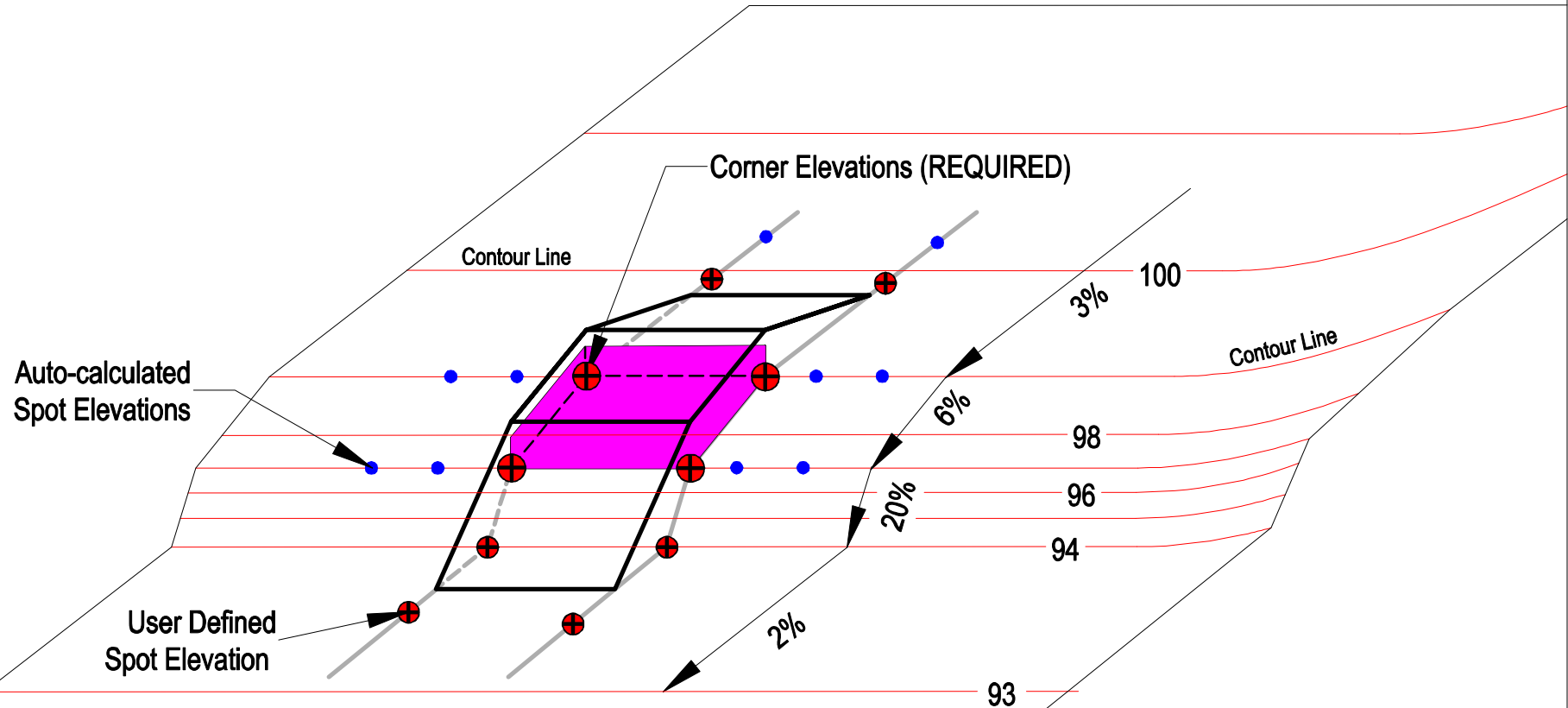

Notes:

1. If spot elevations are not entered then slopes away from the system are automatically calculated based on the 4 corner elevations.

Compound Grades - Figure 1b

Compound Grade input window with sample data for situation shown in Figure 1a.

Compound Grades

Define spot elevations using a Length - Elevation pair [Len. [feet] - Elev. [inches]] in the form below.
 The user may enter 4 spot grades based on each corner of the disposal field.
 All lengths are measured square from the edge of the disposal field. See SeptiCAD Help for more information

Len. Elev. Len. Elev.

Len. Elev. Len. Elev.

Top of System
 Input data for designs on compound slopes.

Left-side: If no data is entered then slope of ground surrounding system will be extrapolated based on elevations of system corners.
 Right-side: Four spot grades can be defined based on each system corner.

Bottom of System

Len. Elev. Len. Elev.

Len. Elev. Len. Elev.

Len. Elev. Len. Elev.

Len. Elev. Len. Elev.

Okay Cancel Refill

INPUT NOT REQUIRED: Data automatically determined based on the elevation of the system corners or a corner elevation and an adjacent spot grade.

Corner elevations entered in Main window

Corner Elevations:

-50 UPSLOPE (TOP) -50

LEFT BEARING → RIGHT

DOWNSLOPE (BOTTOM)

-65 -65

Input Compound Grades

Cross Section for field data shown above

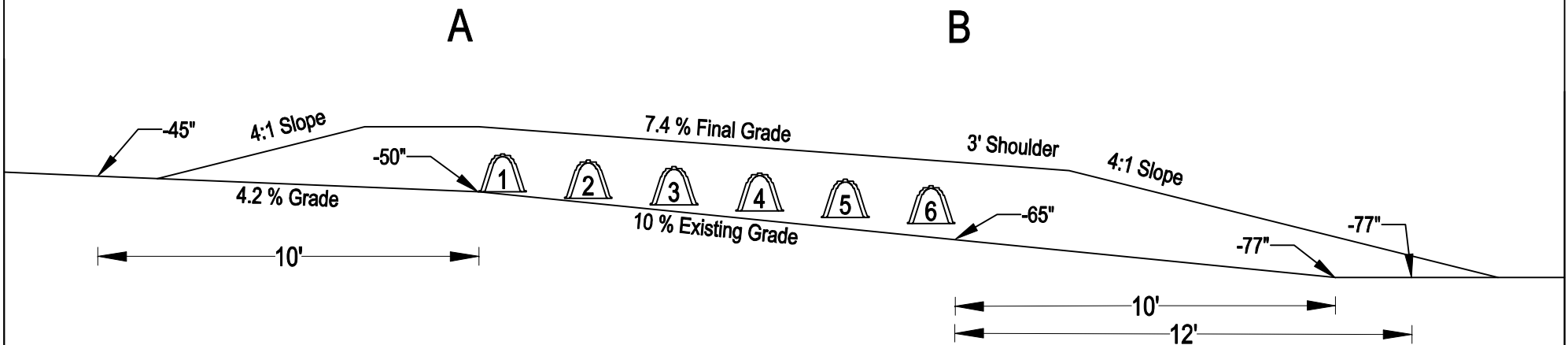

Compound Grades - Figure 2a

LEGEND

- ⊕ Corner Elevations (REQUIRED)
- ⊕ User Defined Spot Elevation (See Note 1)
- Auto-calculated Spot Elevation (See Note 1)

Notes:

1. If spot elevations are not entered then slopes away from the system are automatically calculated based on the 4 corner elevations.

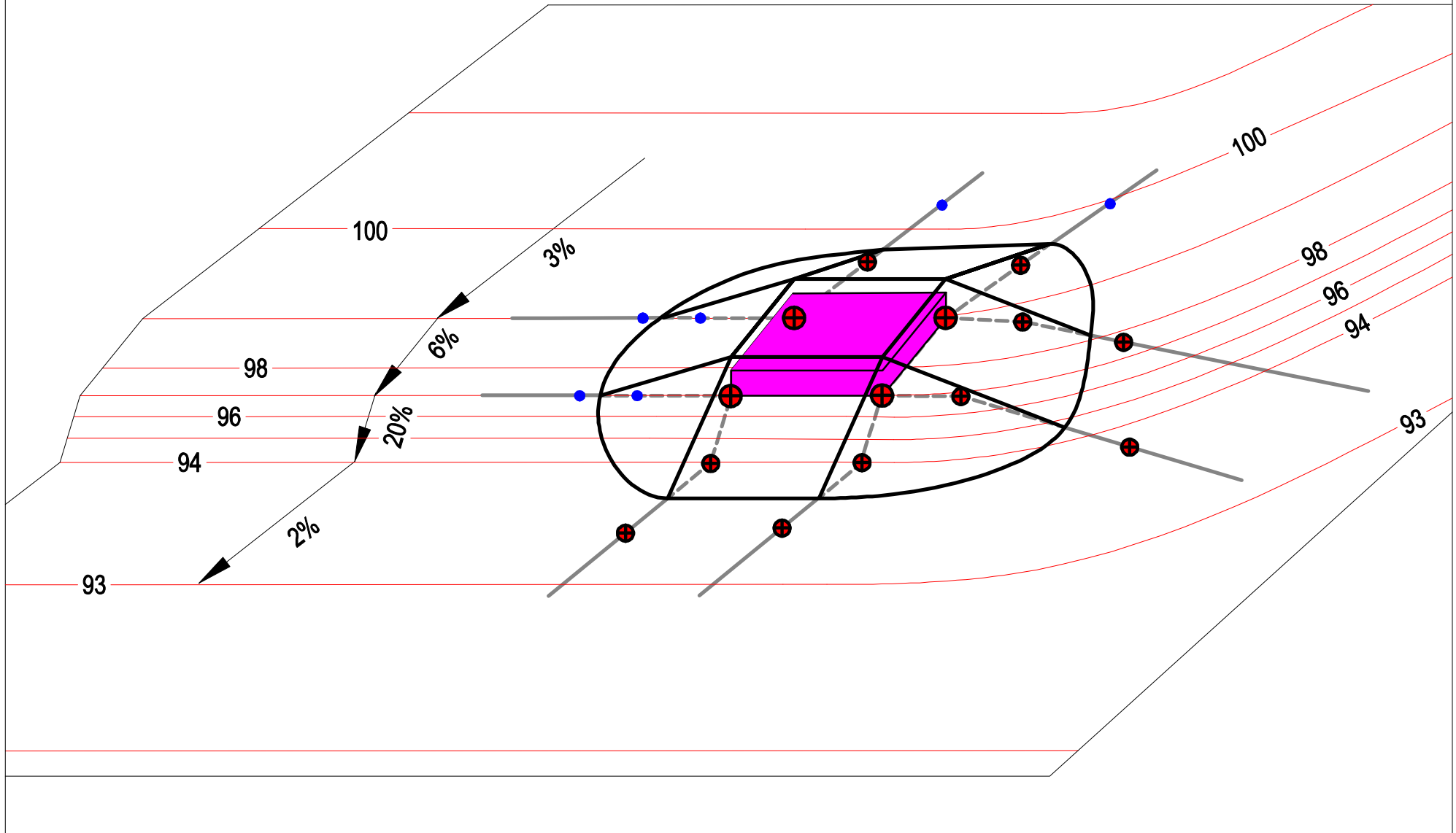

Compound Grades - Figure 2b

Compound Grade input window with sample data for situation shown in Figure 1a.

INPUT NOT REQUIRED: Data automatically determined based on the elevation of the system corners or a corner elevation and an adjacent spot grade.

Corner elevations entered in Main window

Cross Section is Same as in Figure 1b.
A comparison of the Page 3 Maps is depicted below.

Fill Extension for Data shown in Figure 1b

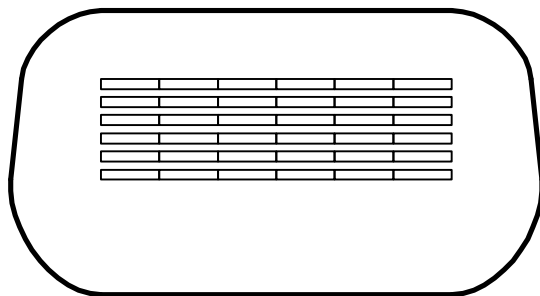

Fill Extension for Data shown above

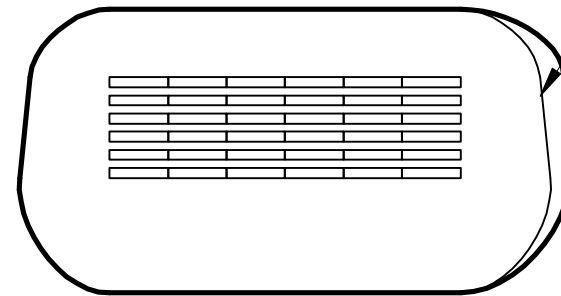

Fill from Figure 1b



Compound Grades - Figure 3a

LEGEND

- ⊕ Corner Elevations (REQUIRED)
- ⊕ User Defined Spot Elevation

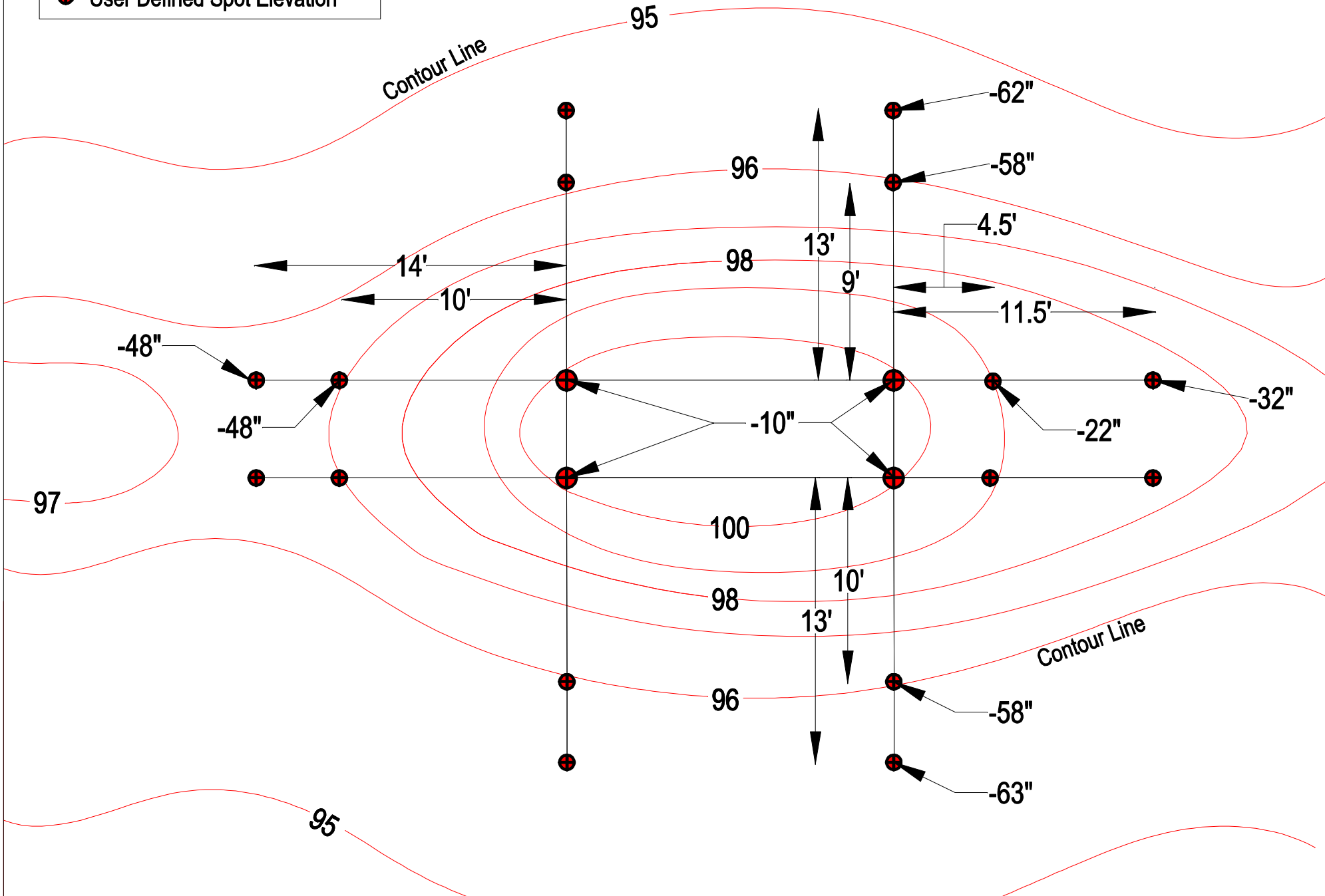

Compound Grades - Figure 3b

Compound Grades

Define spot elevations using a Length - Elevation pair (Len. [feet] - Elv. [inches]) in the form below.
 The user may enter 4 spot grades based on each corner of the disposal field.
 All lengths are measured square from the edge of the disposal field. See SeptiCAD Help for more information

Len. 13 Elv. -62 Len. 13 Elv. -62

Len. 9 Elv. -58 Len. 9 Elv. -58

A

Top of System
 Input data for designs on compound slopes.
 If no data is entered then slope of ground surrounding system will be extrapolated based on elevations of system corners.
 Four spot grades can be defined based on each system corner.

Left-side Right-side

Bottom of System

Len. 14 Elv. -48 Len. 10 Elv. -48 Len. 4.5 Elv. -22 Len. 11.5 Elv. -32

Len. 14 Elv. -48 Len. 10 Elv. -48 Len. 4.5 Elv. -22 Len. 11.5 Elv. -32

Len. 10 Elv. -58 Len. 10 Elv. -58

Len. 13 Elv. -63 Len. 13 Elv. -63

Okay Cancel Refill

Compound Grade input window for field data shown on Figure 3a.

Cross Section for field data shown on Figure 3a.

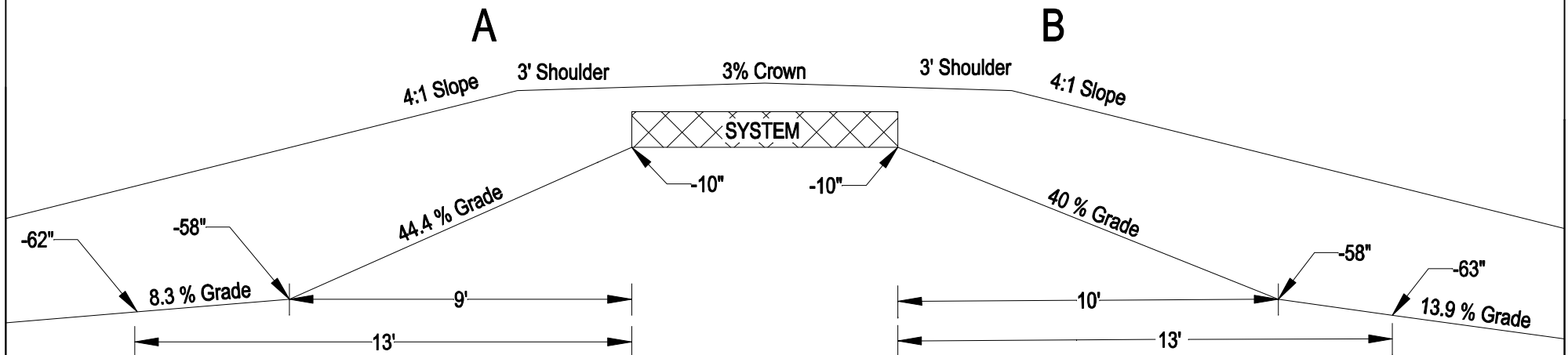

NOTE: The labeling of the cross section has been modified for clarity. Drawing is not to scale.